

OFFICE
SEATING
HANDBOOK

28

29



Assembly Steps, Montage stappen, Montageschritte, Montage du produit :











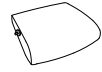
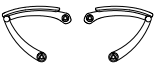
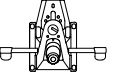



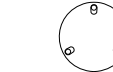



Step 1

- E** Attach the mechanism D to the seat cushion B, fasten with the screws K and screw L. Attention: screws K is for the front of seat cushion, screws L is for the back of seat cushion.
- NL** Bevestig het mechaniek D aan de zitting B, gebruik de bouten K en L. Bouten K zijn voor de voorkant van de zitting en bouten L zijn voor de achterkant.
- D** Montieren Sie den Mechanismus D an den Sitz B mit den Schrauben K und L. Schrauben K vorne und Schrauben L Rückseite

Step 2

- E** Assemble the seat cushion B with backrest A. Before tighten the screw M, please add flat washer P and spring washer Q into the screw M. Finally tighten the screws that connect the backrest A with mechanism D.
- NL** Bevestig de rug A aan de zitting B met de bouten M, vergeet niet P en Q tie te voegen.
- D** Montieren Sie die Rückenlehne A an den Sitz C mit die Schrauben M, P und Q.

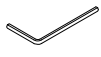
COMPONENTS

A		1PCS	B		1PCS	C		1SET
D		1PCS	E		1PCS	F		5PCS
G		1PCS	H		2PCS	I		2PCS
J		4PCS	K	 8MM x 32MM	2PCS	L	 8MM x 25MM	2PCS
M	 8MM x 19MM	3PCS	N	 8MM x 22MM	2PCS	O	 8MM x 29MM	2PCS
P		5PCS	Q		5PCS	R		2PCS
S		1PCS	T		1PCS	U		1PCS

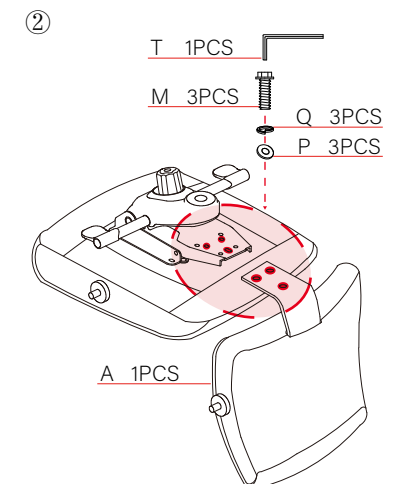
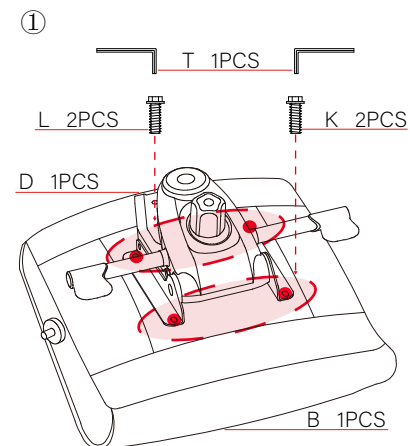

Assembly Steps, Montage stappen, Montageschritte, Montage du produit :

Step 3

E Attached the armrest C to the back and seat. Do not tighten yet. When the right and left armrests are attached, tighten first the bolts N at the backrest after that for the seat O. When tightened, you can attach the cover plates H and I.

Bevestig de armleningen aan de rug en zitting. Nog niet helemaal vast draaien.

NL Als rechts en links bevestigd zijn, draai dan eerst de bouten van de rug vast N en daarna van de zitting O. Daarna kunt u de afdekplaatjes H en I bevestigen.

Befestigen Sie die Armllehnen an Rücken und Sitz. Noch nicht ganz festziehen.

D Wenn rechts und links angebracht sind, ziehen Sie zuerst die Bolzen der Rückseite N und dann des Sitzes O fest. Sie können dann die Abdeckplatten H und I anbringen.

Step 4

E Insert the castors F and the gas lift G to the base E. Then place the dust cover U on the gas lift G.

NL Steek de wieltjes F en de gas lift G in het voetenkruis E. Daarna kunt u het beschermkapje U over de lift G laten zakken.

D Stecken Sie die Räder F und die Gas Feder G in den Fuß E. Danach können Sie den Schutzhülle U über die Feder G herab lassen.

③

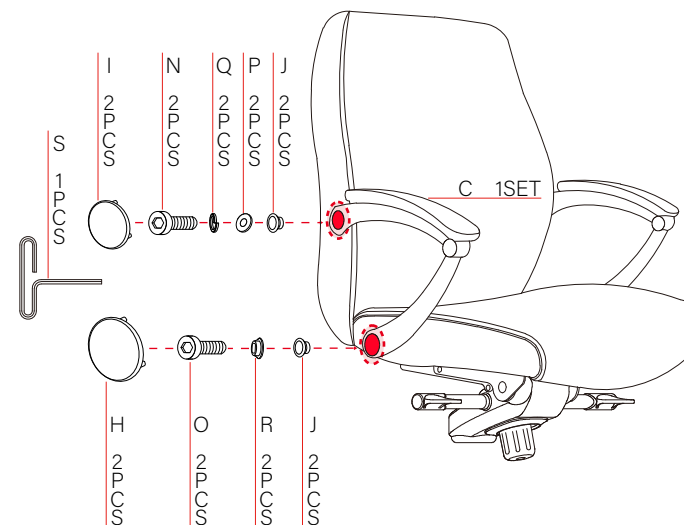

④

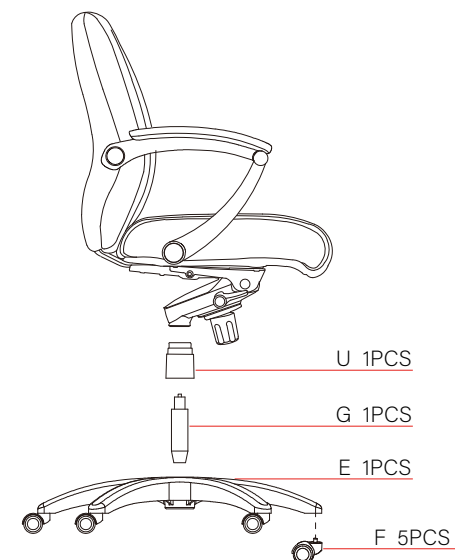

User manual, Gebruiksaanwijzing, Gebrauchsanweisung, Mode d'emploi

- E** With the handle on the left side, you can adjust the backrest angle. When it is unlocked, you can also adjust the tilting tension: The mechanism front (big) knob is to control the backrest tilting tension.
- NL** Met de handel aan de linkerkant, kunt u de hoek van de rugleuning instellen/vastzetten.
- D** Mit dem Hebel an der linken Seite, können Sie den Winkel der Rückenlehne einstellen/feststellen.

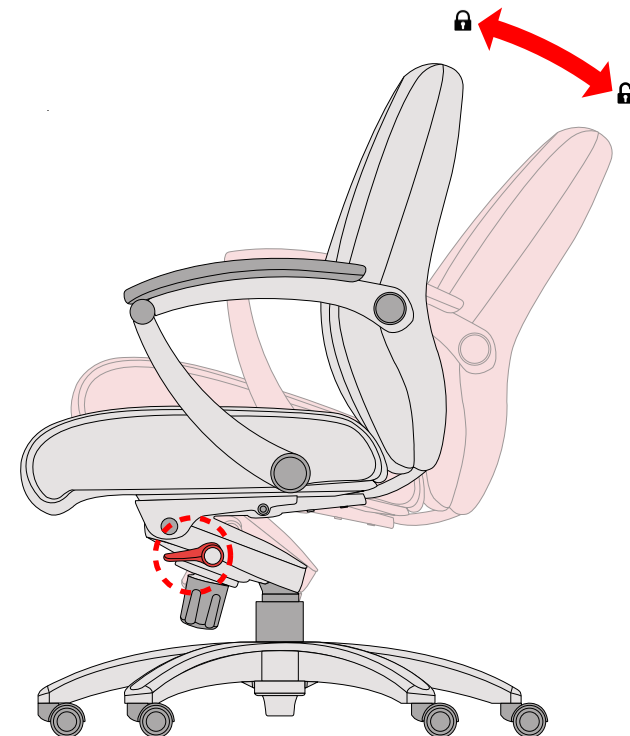
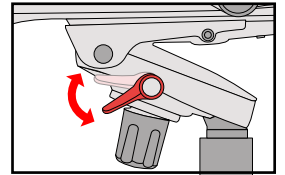

User manual, Gebruiksaanwijzing, Gebrauchsanweisung, Mode d'emploi

- E** Adjust it clockwise to tight the tilting tension, anticlockwise to loosen the tilting tension.
- NL** Als de rugleuning niet is vastgezet, kunt u de tegendruk van de rugleuning instellen d.m.v. de grote knop midden onder het mechaniek (+/-).
- D** Wenn die Rückenlehne nicht festgestellt ist, können Sie den Gegendruck der Rückenlehne einstellen mit dem großen Knopf in der Mitte unter der Mechanik (+/-).

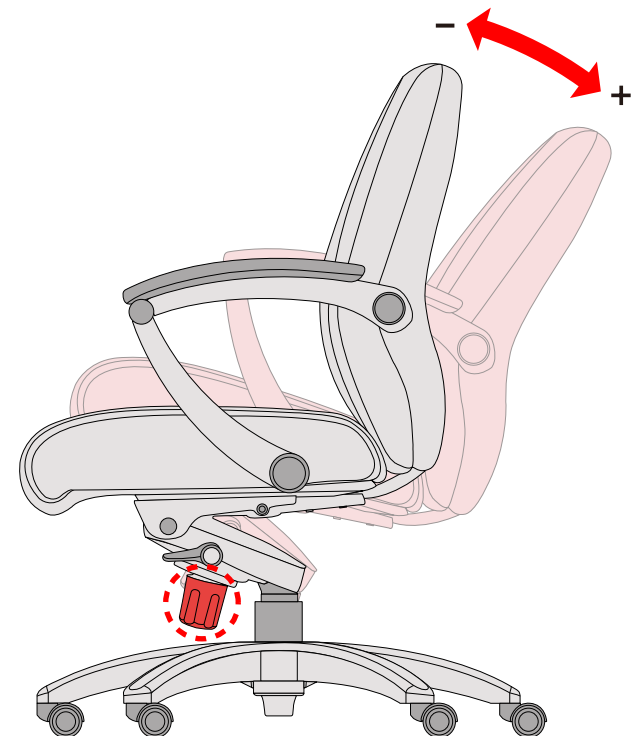
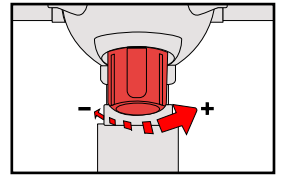

User manual, Gebruiksaanwijzing, Gebrauchsanweisung, Mode d'emploi

- E** By using the handle on the right, you can adjust the seat-height.
- NL** Met de handel aan de rechterkant kunt u de zithoogte instellen.
- D** Mit dem Hebel an der Rückseite können Sie die Sitzhöhe einstellen.

